



Dear Parents,

This math packet is for rising 6th graders and is designed to help your son practice his math skills over the summer months. We know how easy it is to forget something you learned unless you practice it. We hope that by completing this packet your son will get off to a strong start in math in August. The problems in the packet should be familiar to him. If he does not understand something, please encourage him to watch a video about it on YouTube or to search for the topic on the Internet.

The packet is optional, however it is highly recommended. The packet should give you an idea of the different topics your son may need to review prior to the opening of school in August. He can use Khan Academy to get additional practice if he needs it.

Also, please make sure your son knows his math facts. If he does not know them automatically, please practice them with him this summer. While driving in the car, ask him random times table facts or to count up by a certain number. If he is using mental energy to recall these facts, it makes it harder for him to learn new material and make connections so it is important that they are mastered.

We hope you and your family enjoy these summer months, and we look forward to welcoming your son to Young Men's Preparatory Academy!

Sincerely,

Pierre R. Edouard

Pierre Edouard

Name: _____ Class: _____ Date: _____ ID: A

Summer Math Skills for incoming 6th Grade (Must Show All Work and Attach Scrap paper for Full Credit)

Complete the statement with <, >, or =.

1. $4.5 \underline{\quad} 5.4$
2. $16.64 \underline{\quad} 16.57$
3. $0.32 \underline{\quad} 0.320$

Complete the statement.

4. $3 \text{ qt } 2 \text{ pt} = \underline{\quad} \text{ pt}$
5. $87 \text{ in.} = \underline{\quad} \text{ yd } \underline{\quad} \text{ ft } \underline{\quad} \text{ in.}$

Find the sum, difference, product, or quotient.

6. $162 \div 6$
7. $273 - 148$
8. 37×22
9. $407 - 53$
10. $18 + 294$

Find the value of the power.

11. 9^3
12. 6 cubed
13. 14 squared

Evaluate the expression.

14. $34 - 16 + 7$

15. $14 + 8 \div 2$

16. $7 \times 6 + 12 \div 4$

17. $16 + p = 22$

18. $42 = d - 35$

19. $a + 6 = 11$

Evaluate the expression when $x = 3$ and $y = 7$.

20. $6x \div 2 + y$

21. $y^2 - 2x$

Find the mean, median, mode(s), and range of the data.

22. Number of pieces of mail: 4, 8, 6, 2, 0, 3, 7, 5, 8, 2

23. Average inches of rainfall each month: 3, 2, 3, 3, 3, 4, 3, 4, 5, 4, 4, 4

Write the number as a decimal.

24. eighty-nine ten thousandths

25. twenty-six and fourteen hundredths

Write the decimal in words.

26. 10.362

27. 0.0793

Name: _____

ID: A

28. Write 13.015 in words.

Find the sum or difference.

29. $4.3 + 8.9$

30. $15.6 - 7.7$

31. $9.41 - 5.4$

32. $0.0125 + 0.137$

33. $\frac{11}{24} + \frac{7}{24}$

34. $\frac{2}{5} + \frac{7}{20}$

35. $8\frac{9}{16} - 5\frac{5}{8}$

36. $15.2 + 18.71$

37. $13.1 - 7.36$

38. $\frac{7}{9} - \frac{4}{9}$

39. $8\frac{1}{4} - 3\frac{2}{3}$

Find the product or quotient.

40. 3×7.64

41. 4.3×0.005

42. $0.45 \div 0.09$

Name: _____

ID: A

43. 1.9×7.2

44. $101.47 \div 3.65$

45. $1\frac{1}{5} \times 1\frac{1}{3}$

Use the distributive property to find the product.

46. $4(6 + 3.9)$

47. $6(48)$

Find the product or quotient.

48. 21.3×100

49. 58.74×0.01

50. $715 \div 1000$

51. $0.36 \div 0.1$

52. 1.86×0.01

Find the GCF of the numbers.

53. 16, 28

54. 24, 38

55. 36, 81

56. 28, 76

Write two fractions that are equivalent to the given fraction.

57. $\frac{3}{7}$

Name: _____

ID: A

58. $\frac{1}{9}$

59. $\frac{4}{5}$

Tell whether the fraction is in simplest form. If not, simplify it.

60. $\frac{7}{84}$

61. $\frac{24}{32}$

62. $\frac{9}{14}$

63. $\frac{36}{48}$

Find the LCM of the numbers.

64. 4, 18

65. 5, 6, 12

Write the decimal as a fraction or mixed number in simplest form.

66. 0.85

67. 1.12

Find the sum or difference. Write your answer in simplest form.

68. $\frac{5}{9} + \frac{1}{9}$

69. $\frac{4}{15} + \frac{2}{3}$

70. $14\frac{1}{4} - 6\frac{1}{8}$

71. $3\frac{4}{7} + 8\frac{6}{7}$

72. $8\frac{2}{5} - 5\frac{4}{5}$

Find the product or quotient. Write your answer in simplest form.

73. $\frac{5}{9} \times \frac{3}{4}$

74. $3\frac{5}{7} \times 4\frac{3}{8}$

75. A recipe calls for $2\frac{3}{4}$ cups of flour. You already measured $1\frac{2}{3}$ cups. How much more flour do you need?

76. You bought 9 feet of elastic to make hair ties. Each hair tie needs $3\frac{3}{8}$ inches of elastic. How many hair ties can you make?

Write the unit rate.

77. $\frac{432 \text{ words}}{6 \text{ minutes}}$

78. $\frac{48 \text{ yards}}{8 \text{ seconds}}$

Solve the proportion.

79. $\frac{a}{12} = \frac{6}{36}$

80. $\frac{42}{b} = \frac{3}{8}$

81. $\frac{6}{18} = \frac{c}{24}$

Write the percent as a decimal and a fraction.

82. 36%

83. 71%

Write the fraction or decimal as a percent.

84. 0.047

85. $\frac{13}{20}$

86. $\frac{5}{8}$

87. $\frac{16}{24}$

88. A rectangle has an area of 104 square centimeters. The width is 8 centimeters. What is the length of the rectangle?

Order the numbers from least to greatest.

89. 0.9076, 0.879, 0.937, 0.8912

90. 7.01, 7.2, 7.15, 7.005

91. Order the fractions from least to greatest: $\frac{7}{8}, \frac{3}{4}, \frac{8}{6}, \frac{4}{10}$.

92. Order the numbers from least to greatest: $\frac{9}{5}, 2\frac{2}{3}, \frac{5}{2}, \frac{7}{4}$

93. Sixty students out of eighty say they like the school's cafeteria food. Write this number as a decimal and as a fraction in simplest form.

Change the measurement to the specified unit.

94. $6\frac{1}{2}$ cups to pints
95. 19 feet to yards
96. The scale on a scale drawing is 1 inch : 3 feet. A distance on the drawing is 8 inches. What is the actual distance?
97. Lauren makes \$5.35 per hour babysitting. She babysat for 6.5 hours on Saturday. How much money did she earn? Round your answer to the nearest cent.

Divide. Round to the nearest tenth if necessary.

98. $5\overline{)17.5}$
99. $0.15\overline{)48}$

Find the elapsed time.

100. You've watched 1 hour and 13 minutes of a three-hour video. How much time remains of the video?
- ___ 101. 1:23 P.M. to 8:53 P.M.
- | | |
|----------------|----------------|
| a. 6 h 30 min | c. 10 h 30 min |
| b. 10 h 16 min | d. 7 h 30 min |
- ___ 102. 8:31 A.M. to 4:43 P.M.
- | | |
|----------------|---------------|
| a. 13 h 14 min | c. 8 h 12 min |
| b. 13 h 12 min | d. 7 h 12 min |

Find the area of the rectangle.

103. Find the area of the rectangle.

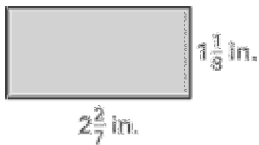

___ 104.

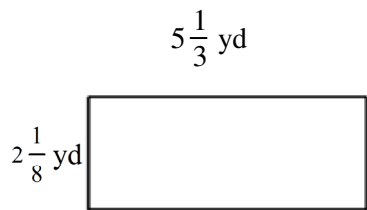

- a. $10\frac{1}{12}$ yd² b. $12\frac{1}{4}$ yd² c. $2\frac{1}{4}$ yd² d. $11\frac{1}{3}$ yd²

105. A map has a scale of 3 cm : 10 km. What is the actual distance between two cities that are 12 cm apart on the map?

Use the diagram.

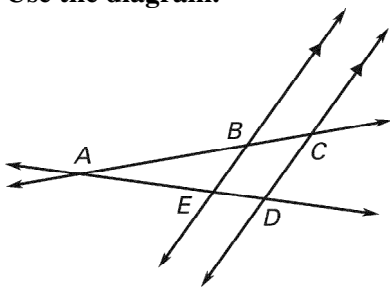

___ 106. Name \overrightarrow{AD} in another way.

- a. \overrightarrow{EA} b. \overrightarrow{AE} c. \overrightarrow{ED} d. \overrightarrow{DA}

___ 107. Which lines are *not* intersecting in the figure?

- a. \overleftrightarrow{DC} and \overleftrightarrow{BA} b. \overleftrightarrow{AC} and \overleftrightarrow{AD} c. \overleftrightarrow{CD} and \overleftrightarrow{EB} d. \overleftrightarrow{ED} and \overleftrightarrow{BC}

108. Name three rays in the figure.

109. Name a segment in the figure that has *D* as an endpoint.

110. Identify two parallel lines in the figure.

111. In the map below, Green Valley Park has a rectangular shape. What is the name of a street that is parallel to Misty Avenue? What is the name of a street that is perpendicular to Misty Avenue?

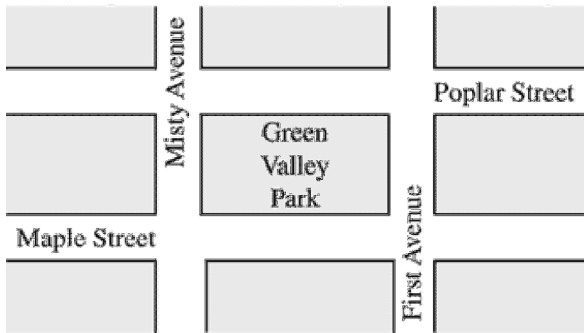

Name the angle in three ways.

- 112.

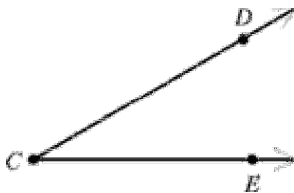

Classify the angle as *acute*, *right*, *obtuse*, or *straight*.

- ___ 113. The measure of angle C is 78° .
 a. straight b. right c. acute d. obtuse

- ___ 114.

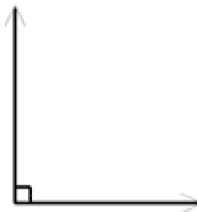

- a. right b. obtuse c. straight d. acute

___ 115. Which pair of angles are vertical angles?

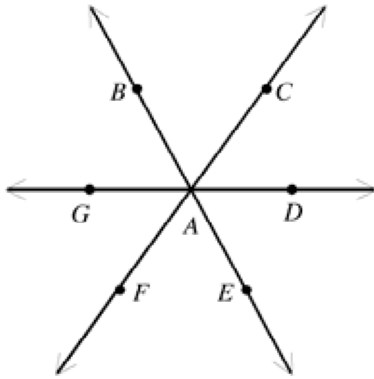

- a. $\angle DAE$ and $\angle DAE$
- b. $\angle BAD$ and $\angle DAE$
- c. $\angle DAE$ and $\angle EAF$
- d. $\angle BAD$ and $\angle GAE$

Use the diagram.

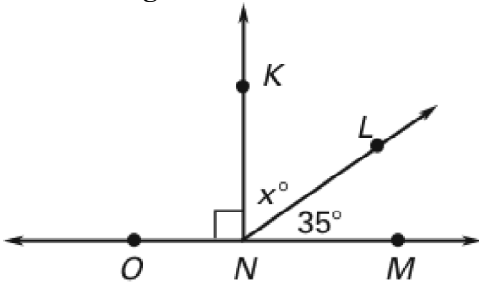

- ___ 116. Identify a pair of complementary angles.
- a. $\angle ONK$ and $\angle LNM$
 - b. $\angle KNL$ and $\angle LNM$
 - c. $\angle KNM$ and $\angle LNM$
 - d. $\angle ONL$ and $\angle LNM$

117. Name a pair of supplementary angles in the figure.

118. Find the value of x in the figure.

Tell whether the angle measures represent angles that are *complementary*, *supplementary*, or *neither*.

- ___ 119. $53^\circ, 37^\circ$
- a. supplementary
 - b. complementary
 - c. neither
- ___ 120. $97^\circ, 83^\circ$
- a. complementary
 - b. neither
 - c. supplementary
- ___ 121. $25^\circ, 55^\circ$
- a. supplementary
 - b. complementary
 - c. neither

- ___ 122. The side of a tent forms a 70° angle with the floor of the tent. If the ground is level, what is the measure of angle x ?

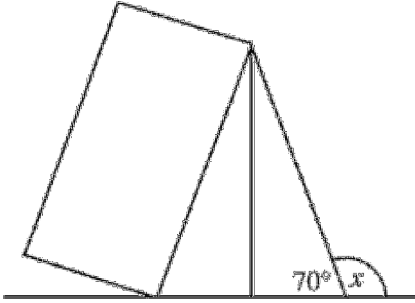

- a. 30° b. 110° c. 130° d. 90°

123. Find the value of x and of y .

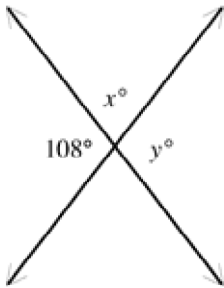

124. $\angle 3$ measures 103° . Find the measure of $\angle 1$.

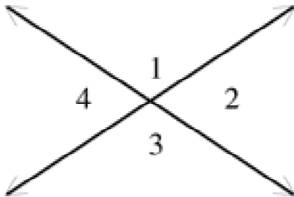

125. Find the value of x .

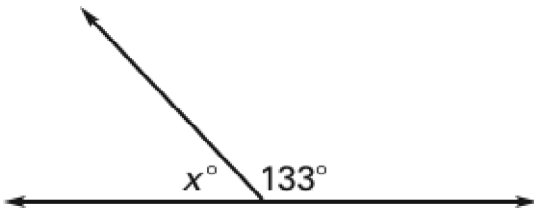

126. What is the measure of $\angle UOV$?

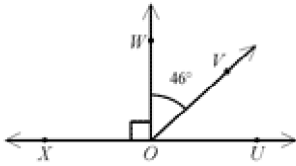

Classify the triangle by its angles.

____ 127.



- a. acute triangle b. right triangle c. obtuse triangle

128.

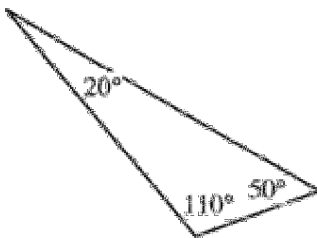

Classify the triangle by its sides.

____ 129.

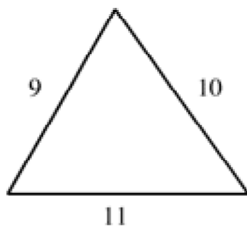

- a. isosceles b. equilateral c. scalene

130.

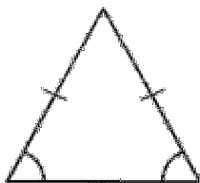

Tell whether the angle measures are those of a triangle. If so, classify the triangle as *acute*, *right*, or *obtuse*.

____ 131. $60^\circ, 30^\circ, 80^\circ$

- a. is a triangle, acute
b. is a triangle, obtuse

- c. not a triangle
d. is a triangle, right

____ 132. $93^\circ, 55^\circ, 32^\circ$

- a. is a triangle, acute
b. is a triangle, right

- c. not a triangle
d. is a triangle, obtuse

133. $112^\circ, 48^\circ, 20^\circ$

Find the value of x .

____ 134.

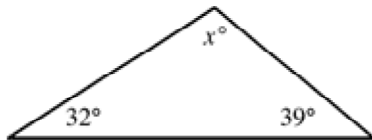

- a. 58 b. 71

- c. 51 d. 109

135.

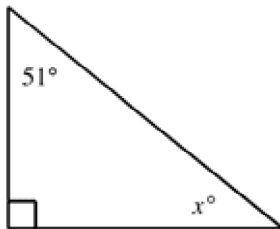

136.

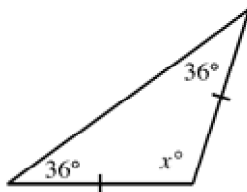

Name: _____

ID: A

___ 137. Find the missing angle measure.

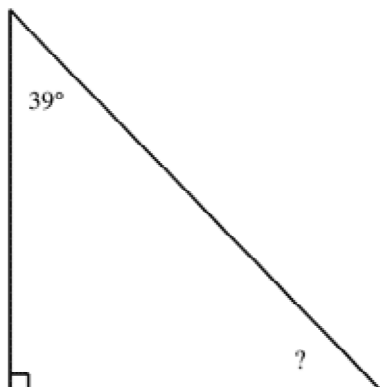

- a. 25° b. 51° c. 23° d. 141°

___ 138. Find the value of n . (The figure may not be drawn to scale.)

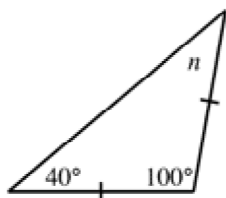

- a. 100° b. 40° c. 50° d. 80°

139. Classify the triangle by its sides.

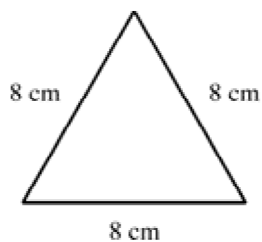

140. Is the triangle below an *acute*, *obtuse*, or *right triangle*?

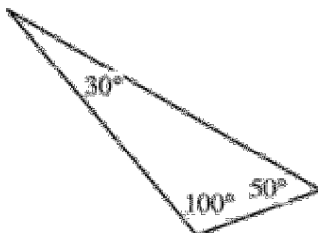

Name: _____

ID: A

Find the value of x .

___ 141.

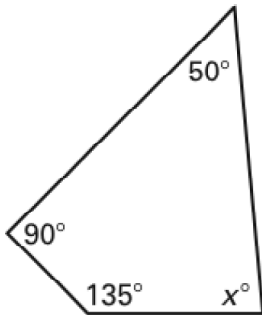

- a. 135 b. 85 c. 90 d. none of these

___ 142.

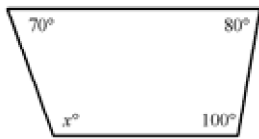

- a. 100 b. 70 c. 80 d. 110

___ 143.

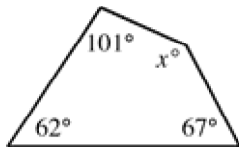

- a. 220 b. 85 c. 40 d. 130

144.

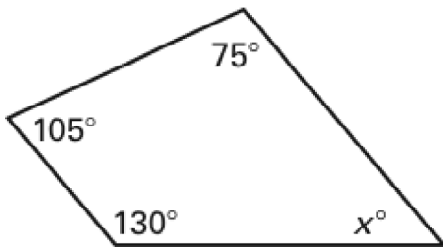

Find the sum or difference.

____ 145. $\frac{17}{20} - \frac{7}{12}$

a. $\frac{11}{40}$

b. $\frac{1}{24}$

c. $\frac{21}{80}$

d. $\frac{4}{15}$

146. $\frac{5}{8} + \frac{1}{10}$

147. $\frac{3}{20} + \frac{1}{5}$

148. $\frac{5}{12} - \frac{1}{6}$

149. Mark's grandmother is making two recipes for Thanksgiving. The first requires $\frac{1}{3}$ of a cup of flour, and the second requires $\frac{1}{2}$ of a cup of flour. How much flour will Mark's grandmother need to make the recipes?

150. To make an outfit for her stuffed animal, Celeste purchased $\frac{1}{4}$ yard of fabric that cost \$5.98 a yard and $\frac{5}{8}$ yard of fabric that cost \$11.39 a yard. How much fabric did Celeste buy?

Find the sum or difference.

____ 151. $9\frac{1}{2} - 2\frac{1}{3}$

a. $7\frac{1}{6}$

b. 8

c. $6\frac{1}{6}$

d. $\frac{2}{31}$

152. $7\frac{13}{19} + 5\frac{5}{19}$

153. $4\frac{2}{3} + 9\frac{3}{4}$

154. $4\frac{7}{8} - \frac{5}{8}$

155. $8\frac{5}{8} - 3\frac{3}{8}$

156. $8\frac{3}{8} - 2\frac{1}{5}$

____ 157. Marissa has $8\frac{3}{7}$ yards of material. Her new skirt will take $3\frac{7}{9}$ yards. How much material will she have left after the skirt is made?

a. $\frac{4}{7}$ yd

b. $11\frac{3}{7}$ yd

c. $4\frac{41}{63}$ yd

d. $3\frac{7}{9}$ yd

158. Anna needed $2\frac{3}{4}$ yards of fabric for a jacket and $3\frac{5}{8}$ yards of fabric for a skirt. How many yards of fabric did she need altogether?

____ 159. Marissa has $7\frac{1}{5}$ yards of material. Her new skirt will take $3\frac{3}{7}$ yards. How much material will she have left after the skirt is made?

a. $3\frac{27}{35}$ yd

b. $10\frac{22}{35}$ yd

c. $5\frac{6}{7}$ yd

d. $7\frac{16}{35}$ yd

160. Jamie has $9\frac{1}{4}$ yards of wire. To make a fence she will need to use $4\frac{2}{3}$ yards. How much wire will she have left after the fence is made?

161. Shelly has $6\frac{2}{5}$ yards of wire. To make a fence she will need to use $1\frac{3}{4}$ yards. How much wire will she have left after the fence is made?

Add or subtract the measures of time.

162. $5 \text{ h } 23 \text{ min } 9 \text{ sec}$

$$+ \underline{8 \text{ h } 2 \text{ min } 2 \text{ sec}}$$

163. Jorge took 30 minutes to get dressed and eat breakfast. He listened to music and cleaned his room for 50 minutes. He then read a book for 1 hour and 15 minutes and worked on a model for 30 minutes before going outside to play. If Jorge started at 7:15 A.M., at what time did he go out to play?

164. The first part of a plane ride lasts 4 hours and 25 minutes. The second part lasts 3 hours and 40 minutes. How much longer is the first part?

Evaluate the expression.

165. $\frac{8}{45} \times 5$

166. $\frac{2}{9} \times \frac{7}{9}$

167. $\frac{6}{5} \times \frac{8}{9} \times \frac{15}{16}$

168. $\frac{3}{5} + \frac{1}{5} \times \frac{2}{3}$

169. $3\frac{1}{7} \times 4\frac{1}{5}$

170. $6\frac{3}{5} \times \frac{2}{5}$

171. Calvin missed $\frac{1}{10}$ of the 60 questions. How many questions did he miss?

172. A pane of glass in a green house measures $1\frac{3}{4}$ feet by $2\frac{1}{2}$ feet. What is the area of the pane of glass?

Find the product.

173. $6 \times 2\frac{2}{3}$

174. $2\frac{1}{7} \times 35$

____ 175. What is the reciprocal of $\frac{6}{19}$?

a. $\frac{19}{6}$ b. $\frac{13}{19}$ c. 6 d. 19

____ 176. What is the reciprocal of $1\frac{1}{4}$?

a. 45 b. $\frac{3}{4}$ c. $\frac{4}{5}$ d. 54

Find the quotient.

177. $\frac{9}{25} \div 15$

178. $\frac{7}{5} \div 2$

179. $\frac{2}{5} \div 1\frac{2}{3}$

180. $4\frac{3}{4} \div 5\frac{1}{4}$

181. $1\frac{1}{3} \div 6$

182. $\frac{11}{15} \div \frac{1}{3}$

183. Phillip is making necklaces. He has 20 yards of string. If Phillip cuts the string into $\frac{5}{7}$ -yard pieces, how many necklaces can he make?

184. A string 30 feet long is to be cut into pieces each $\frac{3}{5}$ of a foot long. How many pieces can be obtained?

____ 185. Diane sold 91 student tickets and 67 adult tickets for a movie. How many tickets did she sell?

a. 159 tickets b. 158 tickets c. 148 tickets d. 149 tickets

Name: _____

ID: A

- ___ 186. Layton received a shipment of 26 boxes of sun-catchers. Each box contained 37 sun-catchers. How many sun-catchers were in the shipment?
- a. 1072 sun-catchers b. 972 sun-catchers c. 962 sun-catchers d. 992 sun-catchers
- ___ 187. A block of provolone cheese weighs 38.2 ounces. How many slices that weigh 2.6 ounces can be cut from the block?
- a. 14 slices c. 15 slices
b. 156 slices d. 146 slices

188. **GRIDDED RESPONSE** Grid the correct answer on a separate gridding sheet.

?, 192, 48, 12, . . .

What number is missing from the sequence above?

Describe the pattern. Then find the next two numbers.

189. 34, 41, 48, 55, ?, ?

190. 7, 21, 63, 189, ?, ?